

CONCERT SERIES



215 COMPACT PROCESSOR CONTROLLED SPEAKER SYSTEM

Applications:

- High SPL Concert Monitors
- Auditorium Installations
- Houses of Worship
- Dance Music

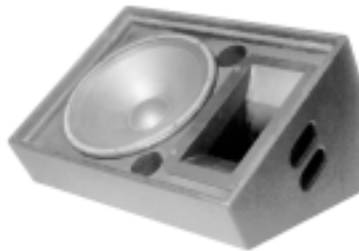

The 215 is a new processor controlled Concert Series speaker system available in either Front of House or Stage Monitor configuration.

215T Front of House

The 215T Front of House enclosure has been created to meet the requirements of sound reinforcement companies around the world. They needed a compact bi-amped processor controlled speaker system with the power to effortlessly cope with the levels required by modern concert productions.

Each 215T cabinet is supplied ready to work, with 4 x ARX 'Ezi-Fly' flying points fitted as standard, dual multipin connectors, sealed handle ports, plus an angling (strapping) point at the bottom.

Its slim trapezoidal design allows it to blend in unobtrusively with existing stage decor, and its premium grade all-plywood construction means it will stand up to a rigorous touring schedule

215M Stage Monitor

The 215M Stage Monitor is designed to give maximum output from an ultra low profile compact enclosure, allowing maximum sightlines while still delivering the punch needed to cut through on stage. With today's high onstage volume levels, accurate and audible vocal monitoring is essential for artists to reach their performance peak. The 215M stage monitor

provides the clarity and level that concert performers require.

Its rugged all ply construction and multi-profile design makes it a true multi-purpose stage monitor that can be used as long throw, short throw or sidefill. A choice of 30°, 60° or 90° angling provides flexible audio control in the most difficult stage environments.

Plus, the unique ARX 'BiPlane' array of multipin connectors is fitted as standard, for fast, mistake proof setups no matter what angle profile is used.

LSP-2 Processor

To ensure accurate, repeatable speaker performance, plus speaker protection and phase alignment, the 215 is designed to be used as a system with the LSP-2 ISC (Interactive System Control™) processor.

This dual channel unit is factory fitted with plug-in cards calibrated and optimized for use with the 215 system. It provides crossover functions, phase correction, EQ correction, and ISC speaker protection.

Unlike simple inline limiters, the 'real-world' time constants used in Interactive System Control are modelled on the human ear response, and provide true system protection without the usual loss of dynamic range.

The ARX 215 is a powerful, compact, and totally professional speaker system. Coupled with the LSP-2, the latest in speaker processing, it delivers truly stunning sound.

The 215T's angled sides (15° taper from front) enables curved arrays to be easily assembled.

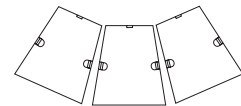

215 Specifications

Each 215 cabinet comprises 1 x 15" (380 mm) Low Frequency driver and 1 x 2" (50 mm) throat titanium diaphragm compression driver in a premium grade, multi laminate plywood enclosure.

The 215T is a trapezoidal design with 4 x 'EziFly' flying points.

The 215M is a multi profile monitor wedge design with a choice of 30°, 60° or 90° angles

Frequency Response

45Hz-20KHz ±5 dB

Impedance

Low 8 ohms
High 16 ohms

Recommended amplifier power

Low 400 W/8 ohm min
High 200 W/8 ohm min

Dispersion -6dB points

90 x 40

Sensitivity

Low 102 dB 1 W/ 1 metre
High 109 dB 1 W/ 1 metre

Maximum SPL @ 1 metre

130 dB +

Connectors

2 x EP4 Male sockets

Maximum Dimensions

18" x 30" x 18"
460 x 770 x 460 mm

Speaker Processor

ARX LSP-2



LSP-2 Speaker Processor

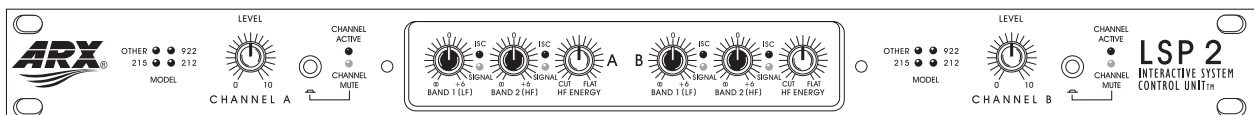

CONCERT SERIES

222

ULTRA LOW PROFILE
PROCESSOR CONTROLLED
STAGE MONITOR SPEAKER



The ARX 222 Stage Monitor is an ultra low profile compact enclosure, allowing maximum sightlines and with the power to effortlessly cope with the high levels of modern concert productions. Its design allows it to blend in unobtrusively with existing stage decor, and its rugged, premium grade all-plywood construction means it will stand up to a rigorous touring schedule.

Like its close relative, the 215M, the 222's unique multi-profile design makes it a true all-purpose stage monitor that can be used as long throw, short throw or side-fill. A choice of 30°, 60° or 90° angling provides flexible audio control in the most difficult stage environments.

Specifications

Each 222 cabinet comprises 2 x 12" (300 mm) Low Frequency drivers and 1 x 2" (50 mm) throat compression driver in a premium grade plywood enclosure. This low profile enclosure is a multi angle (30°, 60°, 90°) monitor wedge design.

Frequency Response

50Hz-20KHz ±5 dB

Impedance

Low 4 ohms
High 16 ohms

Recommended amplifier power

Low 600 W/4 ohm minimum
High 200 W/8 ohm minimum

Dispersion -6dB points

90 x 50

Sensitivity

Low 104 dB 1 W/ 1 metre
High 109 dB 1 W/ 1 metre

Maximum SPL @ 1 metre

130 dB +

Connectors

4 x EP4 or Speakon on unique 'BiPlane' panel

Maximum Dimensions

18" x 36" x 18"
460 x 900 x 460 mm

Speaker Processor

ARX LSP-2

215 ENCLOSURE LAYOUT

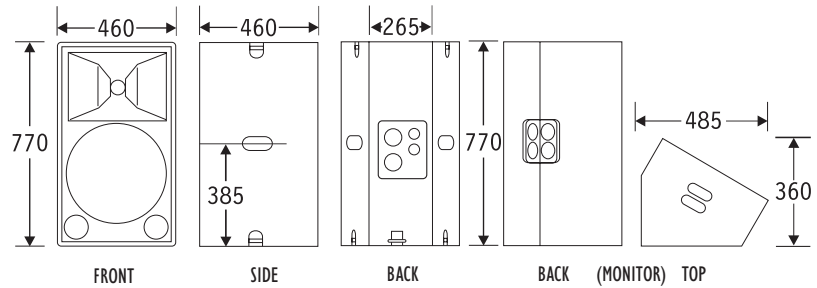

Each 215T cabinet is equipped with sealed handle ports, 4 x ARX EziFly flying points, heavy duty steel mesh, and dual EP or Speakon connectors on a steel plate

Each 215M stage monitor is equipped with a sealed handle port, heavy duty steel mesh, stand insert, multi-angle profile and multiple EP or Speakon connectors on a bi-plane steel plate

215 SYSTEM LAYOUT

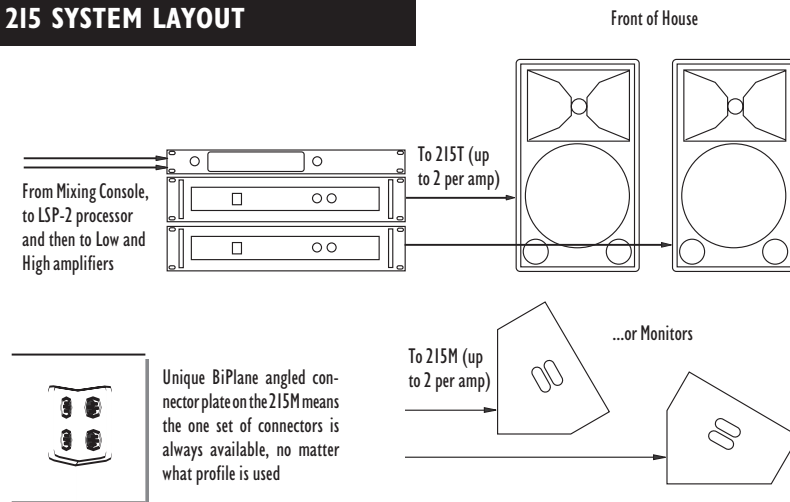

ARCHITECTS' AND ENGINEERS' SPECIFICATIONS

The speaker system shall be an active two way (bi-amped) design, comprising a 380mm (15") low frequency driver and a Ferrofluid cooled 50mm (2") throat compression driver mounted onto a Noryl resin constant directivity high frequency horn. Performance of the speaker system shall be achieved using a dedicated processor. This processor shall be a dual channel unit which shall provide low and high frequency crossover functions via 24 dB per octave filters, phase alignment of the drivers, and amplifier control via a feedback loop.

Rated impedance of the Low Frequency driver shall be 8 ohms. Rated impedance of the High Frequency driver shall be 16 ohms. Sensitivity measured on axis @ 1 metre shall be Low 102 dB, High 109 dB. Frequency response measured @ 1 metre on axis shall be 45 Hz-20 KHz ±5dB. Maximum SPL @ 1 metre on axis shall be 130dB. Dispersion shall be 90° H x 40° V.

The enclosure shall be constructed of premium grade multi laminate plywood and be trapezoidal in shape, with the two sides tapering back at a combined angle of 15°. Dimensions shall be 770mmH x 460mmW x 460mmD (30"H x 18" W x 18" D) and it shall weigh 36 kgs (80lbs). The speaker system shall be the ARX 215T

The stage monitor shall be an active two way (bi-amped) design, comprising a 380mm (15") low frequency driver and a Ferrofluid cooled 50mm (2") throat compression driver mounted onto a Noryl resin constant directivity high frequency horn. Performance of the speaker system shall be achieved using a dedicated processor. This processor shall be a dual channel unit which shall provide low and high frequency crossover functions via 24 dB per octave filters, phase alignment of the drivers, and amplifier control via a feedback loop.

Rated impedance of the Low Frequency driver shall be 8 ohms. Rated impedance of the High Frequency driver shall be 16 ohms. Sensitivity measured on axis @ 1 metre shall be Low 102 dB, High 109 dB. Frequency response measured @ 1 metre on axis shall be 45 Hz-20 KHz ±5dB. Maximum SPL @ 1 metre on axis shall be 130dB. Dispersion shall be 90° H x 40° V.

The enclosure shall be constructed of premium grade multi laminate plywood and be of a low profile monitor wedge shape, with angles of 30, 60 and 90 degrees. Dimensions shall be 770mmH x 460mmW x 460mmD (30"H x 18" W x 18" D) and it shall weigh 36 kgs (80lbs). The stage monitor speaker system shall be the ARX 215M multi-profile monitor wedge.



Specifications available on disk and CD ROM



ARX Systems Pty Ltd, Australia; Phone: +61-3 9555 7859 Fax: +61-3 9555 6747

Our policy is one of continuous improvement, and therefore designs may change without notice. However, unless otherwise stated, specifications will always equal or exceed those previously given.